

Rocktech Displays Limited



Module P/N: RK024HH243-T

Version: 1.0

Description : 2.4 inch TFT 240*320 Pixels
With LED backlight

TEL: 0086-755-26065260

Fax: 0086-755-26065261

E-mail: Sales@rocktech.com.hk

Web: www.rocktech.com.hk

Revision History

Date	Rev.	Page	Description
10/24/2014	1.0	All	First issue

CONTENTS

- n GENERAL FEATURES
- n ABSOLUTE MAXIMUM RATINGS
- n ELECTRICAL SPECIFICATIONS
- n OPTICAL SPECIFICATIONS
- n BLOCK DIAGRAM
- n PIN DESCRIPTION
- n TIMING CHARACTERISTICS
- n OUTLINE DIMENSION
- n RELIABILITY AND INSPECTION STANDARD
- n PRECAUTIONS

1. General Features

Item	Spec	Remark
Display Mode	Normally White transmissive	
Viewing Direction	12 O'CLOCK	
Input Signals	16 bit	
Outline Dimensions	42.72(W) x60.3(H) x3.45(D) Max.	With TP
Active Area	36.72mm(W)×48.96mm(H)	
Number of Pixels	240×RGB×320 Pixels	
Dot Pitch	0.153mm(H)×0.153mm(W)	
Pixel Arrangement	RGB Vertical stripes	
Drive IC	ILI9341V	

2. Absolute Maximum Ratings

The following are maximum values which, if exceeded may cause operation or damage to the unit.

ITEM	Sym.	Min.	Typ.	Max.	Unit	Remark
Power for Circuit Driving	V _{CC}	-0.3	-	4.6	V	
Power for Circuit Logic	V _t	-0.3	-	V _{CC} +0.3	V	
Storage Humidity	H _{ST}	10	-		%RH	At 25±5°C
Storage Temperature	T _{ST}	-30	-	70	°C	
Operating Humidity	H _{OP}	10	-		%RH	
Operating temperature	T _{OP}	-20	-	60	°C	

3. Electrical Specification

3.1 Driving TFT LCD Panel

Item	Sym.	Min	Typ.	Max	Unit	Note	
Power for Circuit Driving	VCC	2.5	2.8	3.3	V		
Power for Circuit Logic	IOVCC	1.65	1.8	3.3	V		
Logic Input Voltage	Low Voltage	V _{IL}	-0.3	-	0.2V _{cc}	V	
	High Voltage	V _{IH}	0.8V _{cc}	-	V _{cc}	V	
Logic Output Voltage	Low Voltage	V _{OL}	0	-	0.2V _{cc}	V	
	High Voltage	V _{OH}	0.8V _{cc}	-	-	V	
Power Consumption	Black Mode	P _b	T.B.D	T.B.D	T.B.D	mW	
	Standby Mode	P _w	T.B.D	T.B.D	T.B.D	mW	

3.2 Driving Backlight

Item	Sym.	Min	Typ.	Max	Unit	Note
Backlight driving voltage	V _F	3.0	3.2	3.4	V	
Backlight driving current	I _F	60	60	80	mA	
Backlight Power Consumption	W _{BL}	-	192	-	mW	
Life Time	-	10,000	20,000	-		Note 3

Note 1: (Unless specified, the ambient temperature Ta=25°C)

Note 2: The recommended operating conditions refer to a range in which operation of this product is guaranteed. Should this range is exceeded, the operation cannot be guaranteed even if the values may be without the absolute maximum ratings.

Note 3: If LED is driven by high current, high ambient temperature & humidity condition. The life time of LED will be reduced. Operating life means brightness goes down to 50% initial brightness. Typical operating life time is estimated data.

4. Optical Specifications

Optical characteristics are determined after the unit has been 'ON' and stable for approximately 30 minutes in a dark environment at 25 °C. The values specified are at an approximate distance 500mm from the LCD surface at a viewing angle of Φ and θ equal to 0°.

Item	Sym.	Values			Unit	Note
		Min.	Typ.	Max.		
1) Contrast Ratio	C/R	350	500	-		FIG.1
2) Module Luminance	L	-	200	-	cd/m ²	With TP
3) Response time	Tr+Tf	-	25	40	ms	FIG.2
4) Viewing Angle	θ_T	50	60	-	Degree	FIG.3
	θ_B	40	50	-		
	θ_L	50	60	-		
	θ_R	50	60	-		
5) Chromaticity	W _x	0.284	0.299	0.314		
	W _y	0.318	0.333	0.348		
	R _x	-	-	-		
	R _y	-	-	-		
	G _x	-	-	-		
	G _y	-	-	-		
	B _x	-	-	-		
	B _y	-	-	-		

Measurement System

Notes:

1. Contrast Ratio(CR) is defined mathematically as :

$$\text{Contrast Ratio} = \frac{\text{Surface Luminance with all white pixels}}{\text{Surface Luminance with all black pixels}}$$
2. Surface luminance is the center point across the LCD surface 500mm from the surface with all pixels displaying white. For more information see FIG 1.
3. Response time is the time required for the display to transition from white to black (Rising Time, Tr) and from black to white (Falling Time, Tf). For additional information see FIG 2.
4. Viewing angle is the angle at which the contrast ratio is greater than 10. The angles are determined for the horizontal or x axis and the vertical or y axis with respect to the z axis which is normal to the LCD surface. For more information see FIG 3.

FIG. 1 Optical Characteristic Measurement Equipment and Method

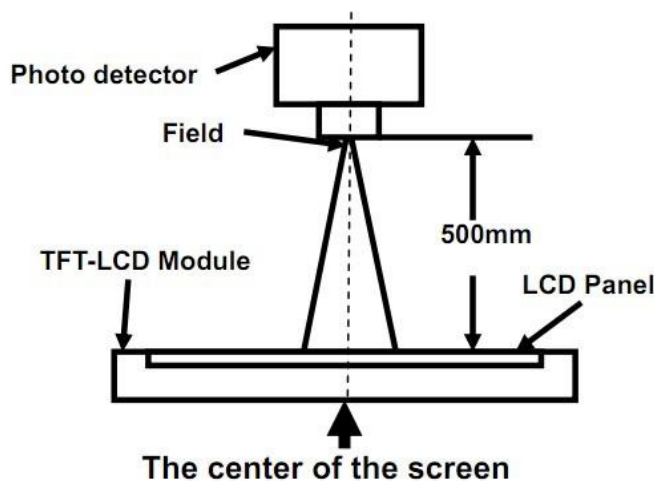

Item	Photo detector	Field
Contrast Ratio	SR-3A	1°
Luminance		
Chromaticity		
Lum Uniformity		
Response Time	BM-7A	2°

FIG. 2 The definition of Response Time

The response time is defined as the following figure and shall be measured by switching the input signal for “black” and “white”.

Response Time = Rising Time(T_r) + Falling Time(T_f)

- Rising Time(T_r) : Full White 90% \rightarrow Full White 10% Transmittance.
- Falling Time(T_f) : Full White 10% \rightarrow Full White 90% Transmittance.

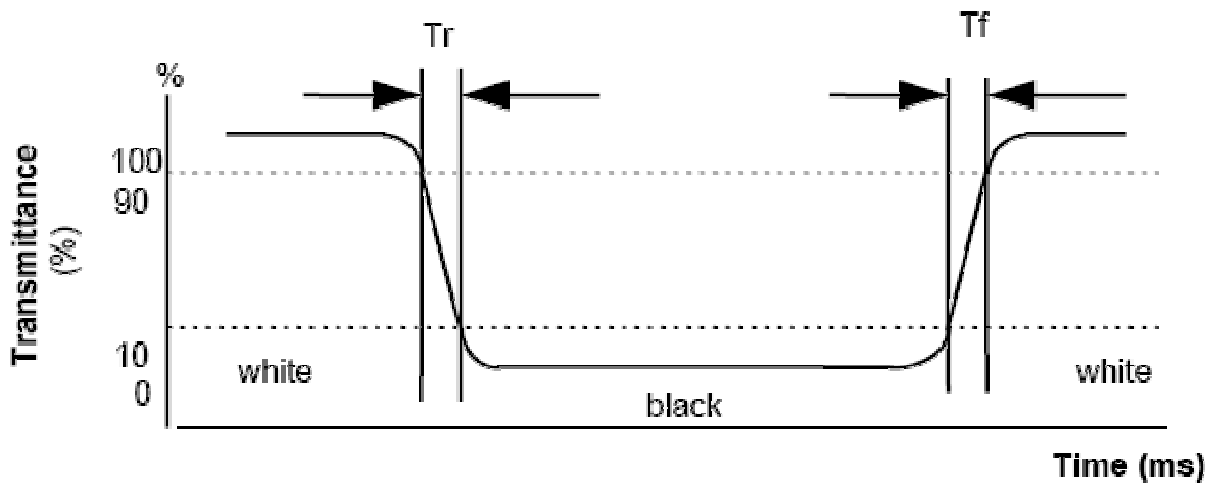
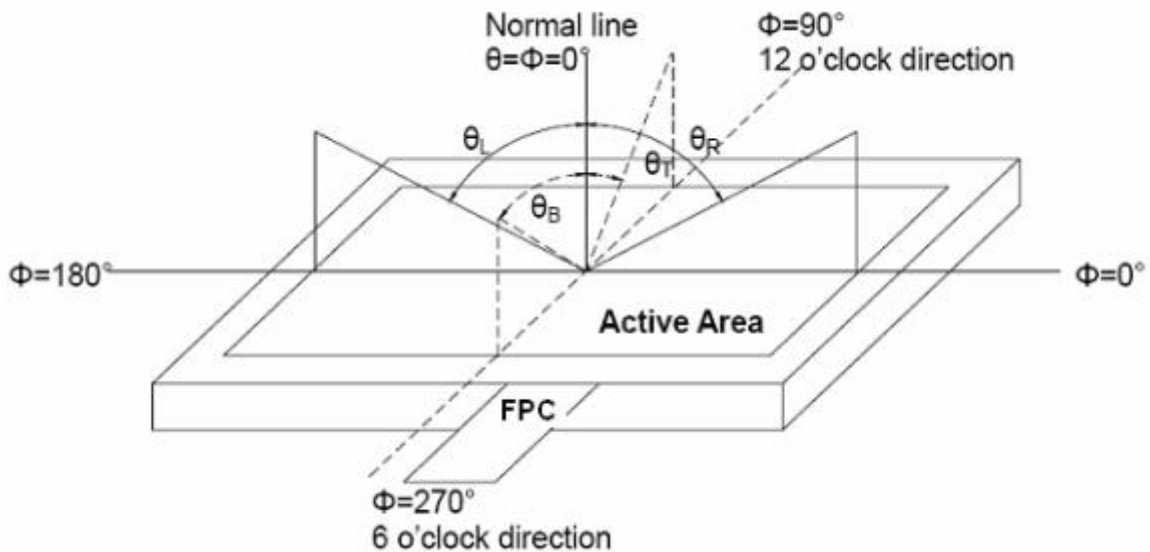
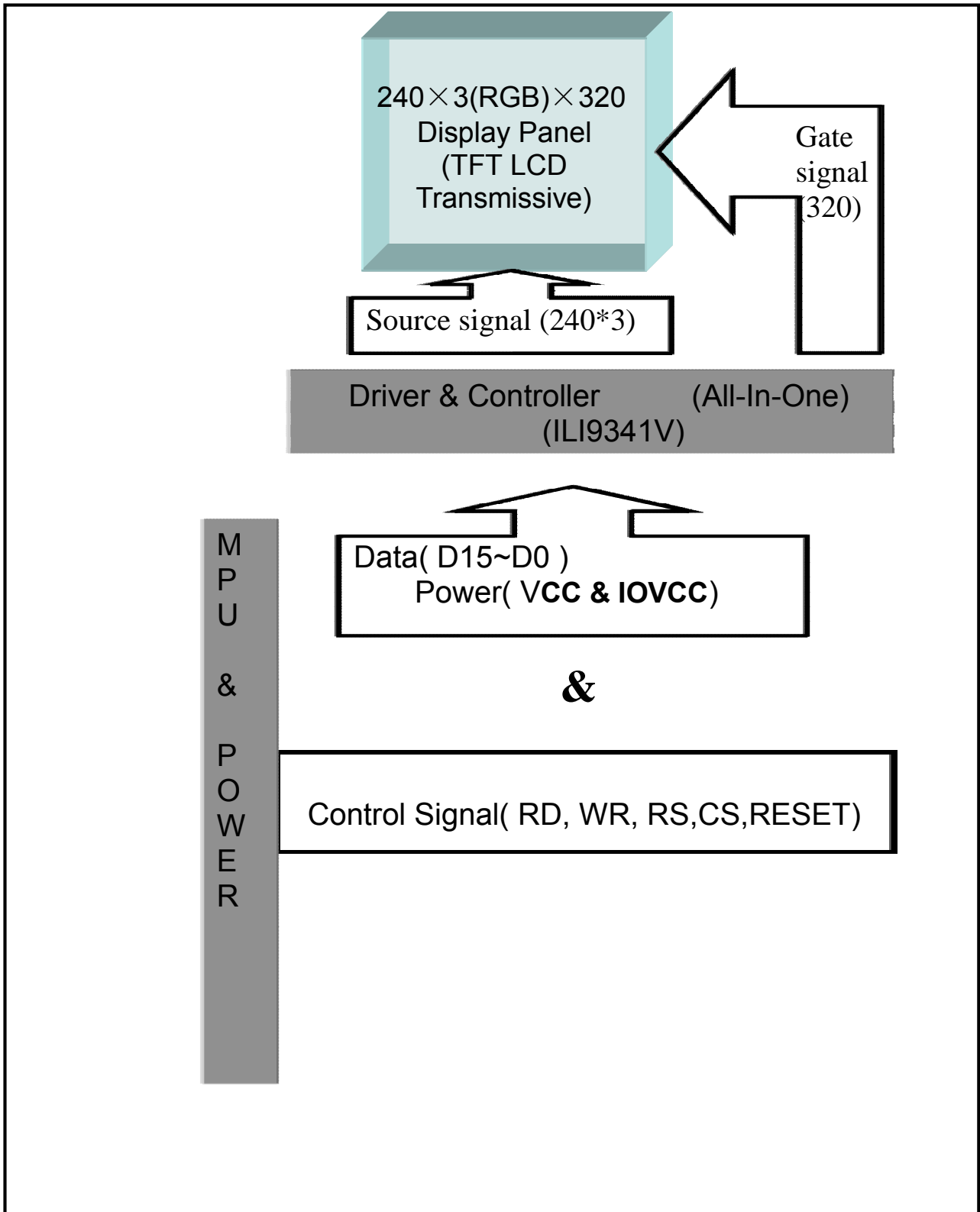

FIG. 3 The definition of Viewing Angle

Use Fig. 1 (Test Procedure) under Measurement System to measure the contrast from the measuring direction specified by the conditions as the following figure.



5. Block Diagram



6.Pin Description

Item	Terminal	Functions
1	DB0	DATA BUS
2	DB1	DATA BUS
3	DB2	DATA BUS
4	DB3	DATA BUS
5	GND	Ground
6	VCC	Power input 2.8V-3.0V
7	CS	Chip Select Input PIN
8	RS	Data&Comand Select PIN
9	WR	Write Data PIN
10	RD	Read Data PIN
11	NC	NC
12	XR	TOUCH PANEL XR
13	YD	TOUCH PANEL YD
14	XL	TOUCH PANEL XL
15	YU	TOUCH PANEL YU
16	LED-A	B/L Power input PIN anode
17	LED-K1	B/L Power input PIN negative
18	LED-K2	B/L Power input PIN negative
19	LED-K3	B/L Power input PIN negative
20	LED-K4	B/L Power input PIN negative
21	NC	NC
22	DB4	DATA BUS
23-30	DB8-DB15	DATA BUS
31	RESET	RESET PIN
32	VCC	Power input 2.8V
33	IOVCC	Power input 1.65V-3.3V
34	GND	Ground
35-37	DB5-DB7	DATA BUS

7. Timing Characteristics

7.1. Parallel Interface Characteristics

Normal Write Mode(HWM='0'), IOVCC=1.65V~3.3V, VCC=2.5V~3.3V

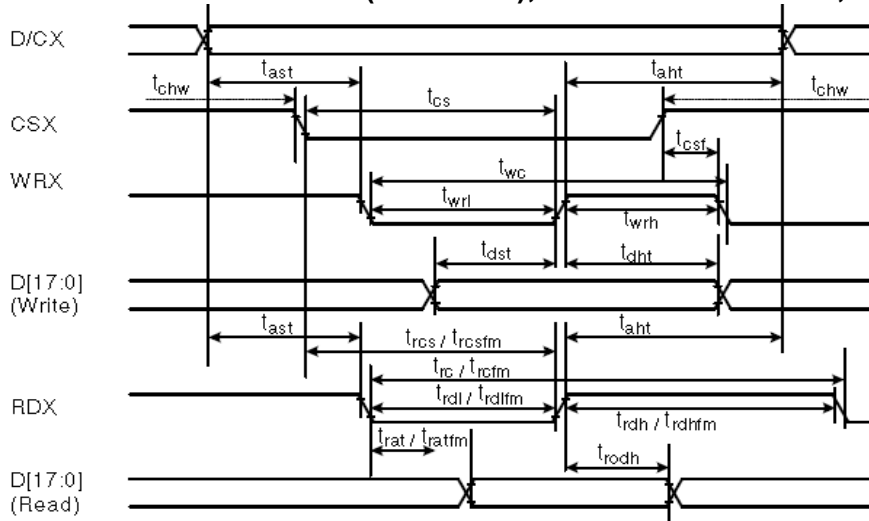

Signal	Symbol	Parameter	min	max	Unit	Description
DCX	t _{ast}	Address setup time	0	-	ns	
	t _{ah}	Address hold time (Write/Read)	0	-	ns	
CSX	t _{chw}	CSX "H" pulse width	0	-	ns	
	t _{cs}	Chip Select setup time (Write)	15	-	ns	
	t _{rcs}	Chip Select setup time (Read ID)	45	-	ns	
	t _{rcsfm}	Chip Select setup time (Read FM)	355	-	ns	
WRX	t _{csf}	Chip Select Wait time (Write/Read)	10	-	ns	
	t _{wc}	Write cycle	66	-	ns	
	t _{wrh}	Write Control pulse H duration	15	-	ns	
RDX (FM)	t _{wrl}	Write Control pulse L duration	15	-	ns	
	t _{rcfm}	Read Cycle (FM)	450	-	ns	
	t _{rdhfm}	Read Control H duration (FM)	90	-	ns	
RDX (ID)	t _{rdlfm}	Read Control L duration (FM)	355	-	ns	
	t _{rc}	Read cycle (ID)	160	-	ns	
	t _{rdh}	Read Control pulse H duration	90	-	ns	
D[17:0], D[17:10]&D[8:1], D[17:10], D[17:9]	t _{rdl}	Read Control pulse L duration	45	-	ns	
	t _{dst}	Write data setup time	10	-	ns	For maximum CL=30pF For minimum CL=8pF
	t _{dht}	Write data hold time	10	-	ns	
	t _{rat}	Read access time	-	40	ns	
	t _{rattm}	Read access time	-	340	ns	
t _{rodh}	Read output disable time	20	80	ns		

7.2 Reset Operation

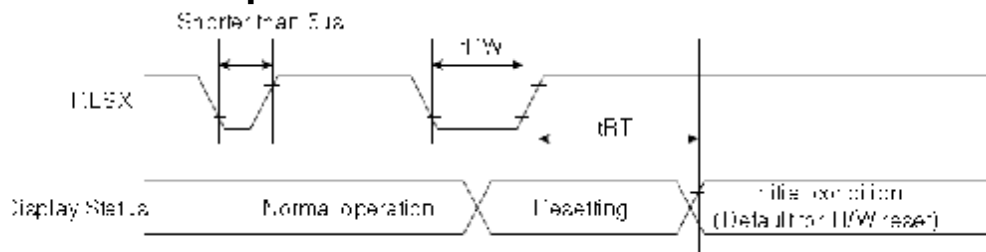

(VDD1=VDD=2.3~3.3 V, Ta= -40~ +85°C)

Parameter	Symbol	Unit	Min.	Typ.	Max.
Reset rise time	t _{rRES}	µs	-	-	10
Reset LOW-level width	t _{RES}	ms-	1	-	-

8. Outline Dimension

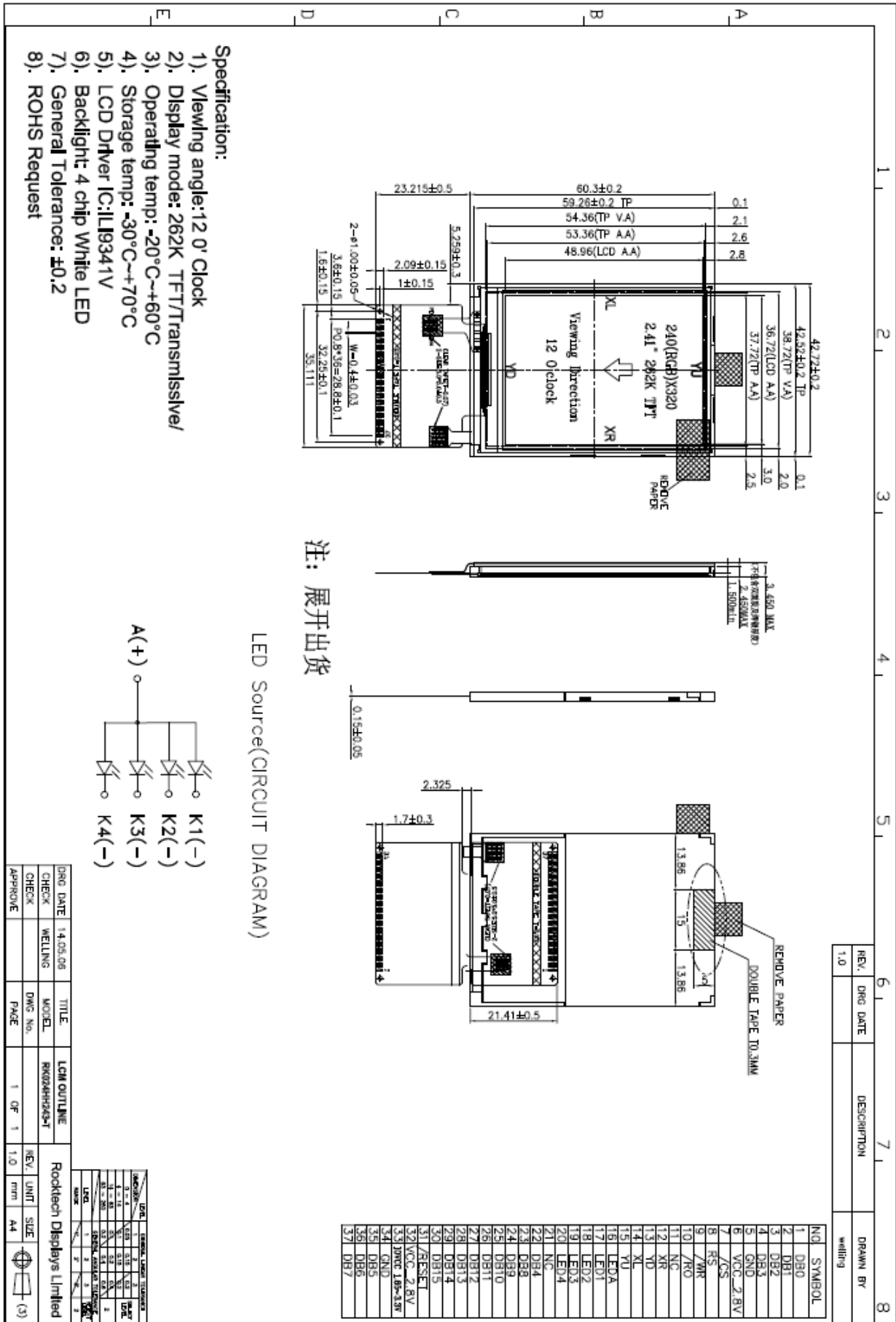

9. Reliability and Inspection Standard

No.	Test Item	Test Conditions	Remark	
1	High Temperature	Storage	70°C, 120Hr	Note
		Operation	60°C, 120Hr	Note
2	Low Temperature	Storage	-30°C, 120Hr	Note
		Operation	-20°C, 120Hr	
3	High Temperature and High Humidity	60°C, 90%RH, 240Hr	Note	
4	Peeling Off (Storage)	$\geq 500\text{gf/cm}$	Note	
5	FPC Bending Test	$\geq 6,000$ times, 2/sec	Note	
6	Vibration Test(Storage)	50HZ, 30min, Amplitude: 2 cm, X/Y/Z directions	Note	
7	Drop Test	60cm/ 3Corner/ 8Face, 1Cycle	Note	

Note:

- 1) The test samples should be applied to only one test item.
- 2) Sample size for each test item is 5~10pcs.
- 3) For Damp Proof Test, pure water(Resistance>1MΩ) should be used.
- 4) In case of malfunction defect caused by ESD damage, if it would be recovered to normal state after resetting, it would be judged as a good part.
- 5) EL evaluation should be excepted from reliability test with humidity and temperature: Some defects such as black spot/blemish can happen by natural chemical reaction with humidity and fluorescence EL has.
- 6) After the reliability test, the test samples should be inspected after 2 hours at least.
- 7) Functional test is OK. Missing segment, shorts, unclear segment, non display, display abnormally, liquid crystal leak are not allowed.
- 8) After testing, the current Idd should be within initial value $\pm 20\%$.
- 9) No low temperature bubbles ,end seal loose and fall, frame rainbow, ACF bubble growing are allowable in the appearance test.

10. PRECAUTIONS FOR USING LCD MODULES

Handling Precautions

- (1) The display panel is made of glass and polarizer. As glass is fragile, it tends to become or chipped during handling especially on the edges. Please avoid dropping or jarring. Do not subject it to a mechanical shock by dropping it or impact.
- (2) If the display panel is damaged and the liquid crystal substance leaks out, be sure not to get any in your mouth. If the substance contacts your skin or clothes, wash it off using soap and water.
- (3) Do not apply excessive force to the display surface or the adjoining areas since this may cause the color tone to vary. Do not touch the display with bare hands. This will stain the display area and degraded insulation between terminals (some cosmetics are determined to the polarizer).
- (4) The polarizer covering the display surface of the LCD module is soft and easily scratched. Handle this polarizer carefully. Do not touch, push or rub the exposed polarizers with anything harder than an HB pencil lead (glass, tweezers, etc.). Do not put or attach anything on the display area to avoid leaving marks on. Condensation on the surface and contact with terminals due to cold will damage, stain or dirty the polarizer. After products are tested at low temperature they must be warmed up in a container before coming is contacting with room temperature air.
- (5) If the display surface becomes contaminated, breathe on the surface and gently wipe it with a soft dry cloth. If it is heavily contaminated, moisten cloth with one of the following solvents
 - Isopropyl alcohol
 - Ethyl alcoholDo not scrub hard to avoid damaging the display surface.
- (6) Solvents other than those above-mentioned may damage the polarizer. Especially, do not use the following.
 - Water
 - Ketone
 - Aromatic solventsWipe off saliva or water drops immediately, contact with water over a long period of time may cause deformation or color fading. Avoid contacting oil and fats.
- (7) Exercise care to minimize corrosion of the electrode. Corrosion of the electrodes is accelerated by water droplets, moisture condensation or a current flow in a high-humidity environment.
- (8) Install the LCD Module by using the mounting holes. When mounting the LCD module make sure it is free of twisting, warping and distortion. In particular, do not forcibly pull or bend the I/O cable or the backlight cable.
- (9) Do not attempt to disassemble or process the LCD module.
- (10) NC terminal should be open. Do not connect anything.
- (11) If the logic circuit power is off, do not apply the input signals.
- (12) Since LCM has been assembled and adjusted with a high degree of precision, avoid applying excessive shocks to the module or making any alterations or modifications to it.
 - Do not alter, modify or change the shape of the tab on the metal frame.
 - Do not make extra holes on the printed circuit board, modify its shape or change the positions of components to be attached.
 - Do not damage or modify the pattern writing on the printed circuit board.

- Absolutely do not modify the zebra rubber strip (conductive rubber) or heat seal connector.
- Except for soldering the interface, do not make any alterations or modifications with a soldering iron.
- Do not drop, bend or twist LCM.

Storage Precautions

When storing the LCD modules, the following precaution is necessary.

- (1) Store them in a sealed polyethylene bag. If properly sealed, there is no need for the dessicant.
- (2) Store them in a dark place. Do not expose to sunlight or fluorescent light, keep the temperature between 0°C and 35°C.
- (3) The polarizer surface should not come in contact with any other objects. (We advise you to store them in the container in which they were shipped).

Others

Liquid crystals solidify under low temperature (below the storage temperature range) leading to defective orientation or the generation of air bubbles (black or white). Air bubbles may also be generated if the module is subject to a low temperature.

If the LCD modules have been operating for a long time showing the same display patterns, the display patterns may remain on the screen as ghost images and a slight contrast irregularity may also appear. A normal operating status can be regained by suspending use for some time. It should be noted that this phenomenon does not adversely affect performance reliability.

To minimize the performance degradation of the LCD modules resulting from destruction caused by static electricity etc., exercise care to avoid holding the following sections when handling the modules.

- Exposed area of the printed circuit board.
- Terminal electrode sections.